



MELINT



LAMPRO⁺
MELINT, official distributor

TYPICAL **FIXED** SOLUTIONS

CONTACT US

Ville Verte,
Ouled ben amer RP 3011 k6,
Casablanca, Morocco.
Tel : +212 (0)522 012 928
Tel : +212 (0)529 044 345
Fax : +212 (0)529 044 201
e-mail : info@melint.com

www.melint.com

Shenzhen LAMP Technology Co., Ltd.

The World's Largest LED Display Manufacture Base



400,000_{sqm}
Largest manufacturing base

Intelligent Factory
Complete automatic production

1300+
Professional skilled staff

As the first batch of certified national high-tech enterprises, it has built a complete R&D, manufacturing, sales, and service system and independent production base, and equipped with first-class R&D, production, and experimental equipment in the two major manufacturing centers, leading the industry in modernization, scale and standardization with 400,000 sqm largest intelligent manufacturing base for LED display screens in the world. It became the "lighthouse factory" in the LED industry, had the same resources of three brands of display sections, could provide LED products and services with an estimated annual revenue of more than 1 billion US dollars.

Relying on the strategic positioning of industry + Internet + Finance, Unilumin introduces advanced production equipment and combines the latest application technology to build smart factories and realize smart production. In terms of efficiency and cost, we will lead the world, upgrade industry 4.0, and bring the manufacturing level into the stander of European and American countries. It has also recruited many high-quality research and development elite teams in the LED industry and trained more than 1,300 professional and skilled employees who control various production chains.

Unilumin **ROE** **LAMPRO**

INDOOR COMMERCIAL DISPLAYS

Page 09-20



BNX/BNA Series

FIXED - INDOOR

BN1.5X / BN1.9X / BN2.5X / BN2.6X / BN3.9X
BN1.5A / BN1.9A / BN2.5A / BN2.6A / BN3.9A



GN PLUS Series

FIXED - INDOOR

GN1.5PLUS / GN1.9PLUS / GN2.6PLUS / GN3.9PLUS

CREATIVE DISPLAYS

Page 37-48



LCF Series

CREATIVE - INDOOR

LCF1.5 \ LCF 2.6

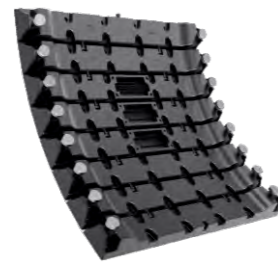

WNX Series

CREATIVE - INDOOR

WN1.9X / WN2.6X / WN2.9X / WN3.9X



WX Series

CREATIVE - OUTDOOR

WX2.9 / WX3.9 / WX4.8 / WX5.9

OUTDOOR COMMERCIAL DISPLAYS

Page 23-34



LST Series

FIXED - OUTDOOR

LST4 / LST6 / LST8 / LST10



LSK Series

FIXED - OUTDOOR

LSK2.6 / LSK2.9 / LSK3.9 / LSK4.8 / LSK5.9



LX Series

FIXED - OUTDOOR

L3.9X / L4.8X / L5.9X

FINE PITCH DISPLAYS

Page 51-62



LMini Series

BRAND NEW COB MINI - INDOOR

LMini0.9 / LMini1.2 / LMini1.5 / LMini1.8



LHP Series

FINE PITCH - INDOOR

LHP0.9 / LHP1.2 / LHP1.5 / LHP1.8 / LHP2.5

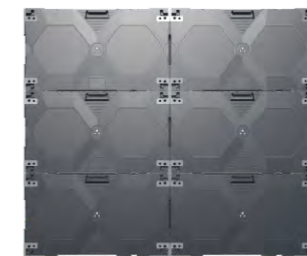

HNA Series

FINE PITCH - INDOOR

HN0.9A/HN1.2A/HN1.5A / HN1.8A

CREATIVE PRODUCT SOLUTIONS

1. BNX / BNA:

Different cabinet sizes can be used together to make multiple screen sizes.

2. GN PLUS+WNX:

Indoor creative solution - flat and curve screen can be together seamless

3. LX+WX:

Outdoor creative solution - flat and curve screen can be together seamless



1. BNX /BNA Series



2. GN PLUS + WNX Series

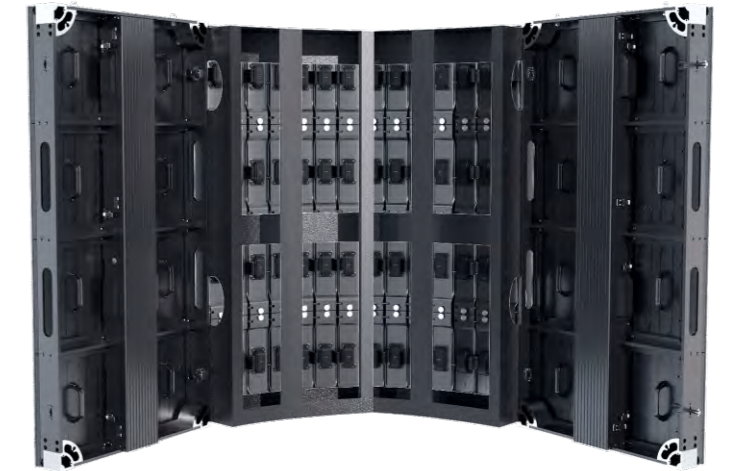

3. LX + WX Series

09 Page + 13 Page

17 Page + 41 Page

31 Page + 45 Page

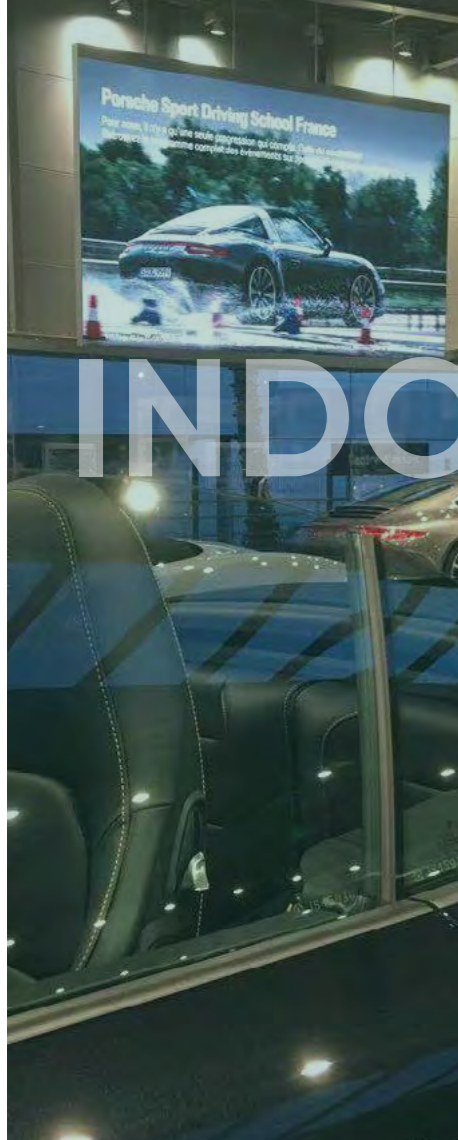

INDOOR

Indoor Event

Public Infrastructures

Luxury Shops

Indoor Advertising

INDOOR COMMERCIAL DISPLAYS

BNX Series

Assemble What You Want It For

09

BNA Series

Remarkable, Practical from All Aspects

13

GN PLUS Series

Conciseness for More Possibilities

17

BNX SERIES

ASSEMBLE WHAT YOU WANT IT FOR

BN1.5X / BN1.9X / BN2.5X / BN2.6X / BN3.9X

Features

- Malposed combination
- Cut-corner screen & corner screen
- Rotated combination
- Cabinets can be mixeal combined
- Curved cabinet optional
- 6 options cabinet

Cabinet size : 500x250/750x250/1000x250/500x1000mm
Customizable cabinet size : 500x500mm/500x750mm

APPLICATIONS: RETAIL SHOPS, CHAIN STORES, TV STUDIOS, CINEMAS, AIRPORTS, MUSEUMS



INDOOR COMMERCIAL DISPLAYS



BNX SERIES

INDOOR

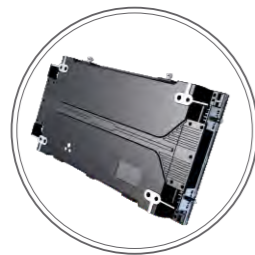

Light as feather, slim as paper



Power&Signal cabling invisible

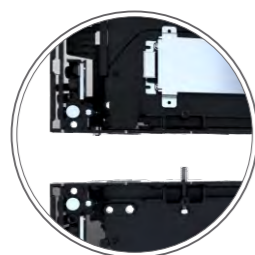

Front installation



FIXED



High quality die-casting aluminum cabinet



Hanging design for small signs and direction board



Cabinets can be mixed combined



Right Angle



Cylinder

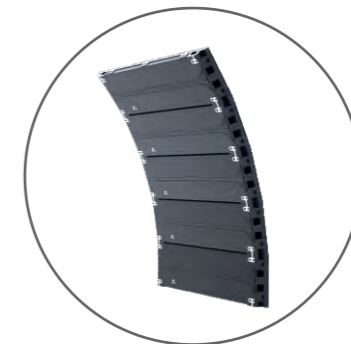

Curved

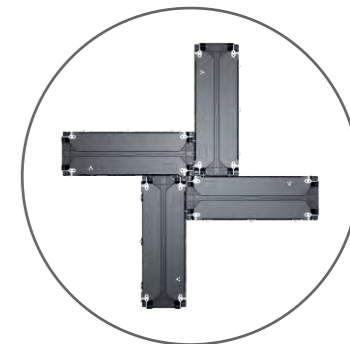

Mal-pesed Splicing

FIXED

Series	BN1.5X	BN1.9X	BN2.5X	BN2.6X	BN3.9X
LED type	SMD1010/1212	SMD1010/1515	SMD2121	SMD2121 / 1515	SMD2121
Pixel pitch	1.5mm	1.9mm	2.5mm	2.6mm	3.9mm
Cabinet Dimensions	500x1000x48 1000x250x48mm	500x500/750/1000x48 & 1000/750/500x250x48mm	500x500/750/1000x48 & 1000/750/500x250x48mm	500x500/750/1000x48 & 1000/750/500x250x48mm	500x500/750/1000x48 & 1000/750/500x250x48mm
Pixel matrix per panel	320x640; 640x160	256x256/384/512 & 512/384/256x128	200x200/300/400 & 400/300/200/100	192x192/288/384 & 384/288/192x96	128x128/192/256 & 256/192/128x64
Pixel density	409600/sqm	262144/sqm	160000/sqm	147456/sqm	65536/sqm
Module size	250x250mm	250x250mm	250x250mm	250x250mm	250x250mm
Weight	12.5/6.3kg/panel	6.4/8/12.5 & 6.3/5/3.7kg/panel	6.4/8/12.5 & 6.3/5/3.7kg/panel	6.4/8/12.5 & 6.3/5/3.7kg/panel	6.4/8/12.5 & 6.3/5/3.7kg/panel
Refresh rate	≥3840Hz	≥3840Hz	≥3840Hz	≥3840Hz	≥3840Hz
Brightness	600nits	600nits	900nits	900nits	900nits
Max power	383w/m ²	438w/m ²	360w/m ²	480w/m ²	438w/m ²
IP rating	IP40 / IP20	IP40 / IP20	IP40 / IP20	IP40 / IP20	IP40 / IP20



User-Friendly



Wide View Angle



Noise Free



Magnet



Fast Installation



Super Slim



Easy Repair



Good Heat Control



High Contrast



High Refresh Rate



BNA SERIES

REMARKABLE, PRACTICAL FROM ALL ASPECTS

BN1.5A / BN1.9A / BN2.5A / BN2.6A / BN3.9A

Features

- Super lightweight and slim
- Full front maintenance
- High flatness
- Highly efficient heat dissipation
- Easy maintenance
- 6 options cabinet

Cabinet size : 500x250 / 750x250 / 1000x250 / 500x1000mm
Customizable cabinet size : 500x500mm / 500x750mm

APPLICATIONS: RETAIL SHOPS, CHAIN STORES, TV STUDIOS, CINEMAS, AIRPORTS, MUSEUMS

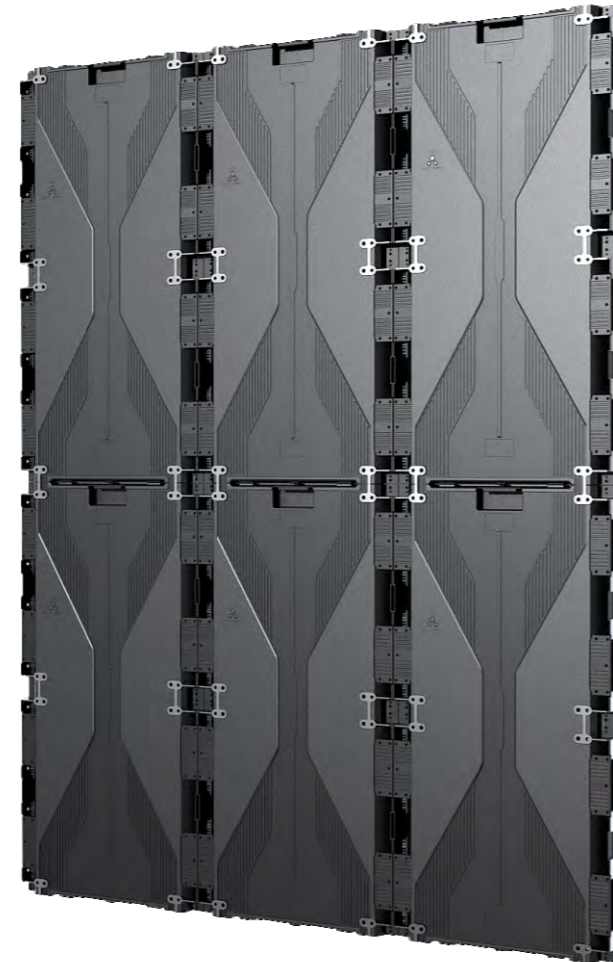

INDOOR COMMERCIAL DISPLAYS

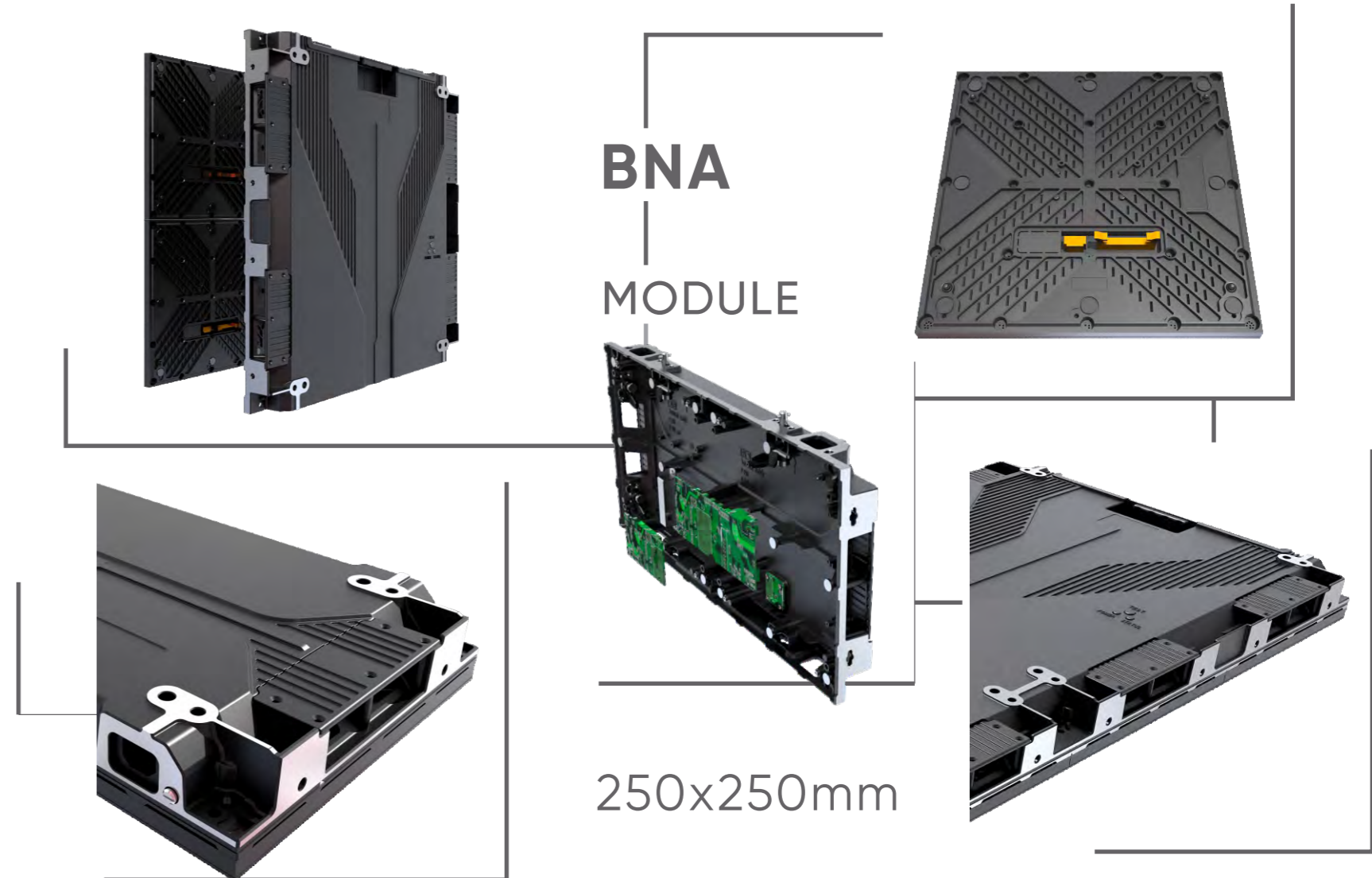

BN1.5A / BN1.9A / BN2.5A
BN2.6A / BN3.9A

BNA SERIES

INDOOR



Light as feather, slim as paper



Power&Signal cabling invisible



Front installation



FIXED



Easy Maintenance



Cabinets can be mixed combined



Maintenance tool



Conventional Splicing



Multidimensional Splicing

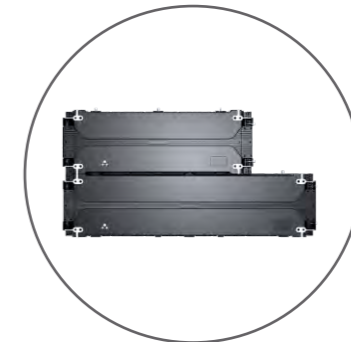

Diverse Sizes Splicing

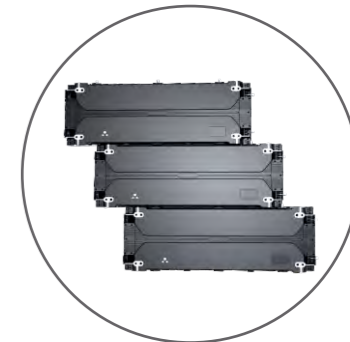

Misalignment Splicing

FIXED

Series	BN1.5A	BN1.9A	BN2.5A	BN2.6A	BN3.9A
LED type	SMD1212	SMD1515	SMD2121	SMD1515	SMD2121
Pixel pitch	1.5mm	1.9mm	2.5mm	2.6mm	3.9mm
Cabinet Dimensions	500x1000mm 1000x250mm	500/750/1000x250mm 500/500/750x1000mm	500/750/1000x250mm 500/500/750x1000mm	500x1000mm 1000x250mm	500x1000mm 1000x250mm
Pixel density	409600/sqm	262144/sqm	160000/sqm	147456/sqm	65536/sqm
Module size	250x250mm	250x250mm	250x250mm	250x250mm	250x250mm
Weight	13.7/7Kg/panel	4/5.4/7/7.3/10.5/13.7Kg/panel	4/5.4/7/7.3/10.5/13.7Kg/panel	13.7/7Kg/panel	13.7/7Kg/panel
Refresh rate	≥3840Hz	≥3840Hz	≥3840Hz	≥3840Hz	≥3840Hz
Brightness	600nits	600nits	600nits	700-750nits	800-900nits
Max power consumption	450w/m²	450w/m²	435w/m²	450w/m²	450w/m²
IP rating	IP40/IP20	IP40/IP20	IP40/IP20	IP40/IP20	IP40/IP20



User-Friendly



Wide View Angle



Noise Free



Magnet



Fast Installation



Super Slim



Easy Repair



Good Heat Control



High Contrast



High Refresh Rate

GN PLUS SERIES

CONCISENESS FOR MORE POSSIBILITIES

GN1.5 PLUS / GN1.9 PLUS / GN2.6 PLUS / GN3.9 PLUS

Features

- The cabinet is symmetric, with tidy and pretty back
- 45° cut-corner and right-angle cabinet are optional
- Front and rear maintenance
- Hanging installation, stacking installation, fast lock, aviation connector, quick installation

APPLICATIONS: SPECIALTY STORES, MEETING ROOMS, MONITORING



INDOOR COMMERCIAL DISPLAYS



GN PLUS
MODULE

250x250mm

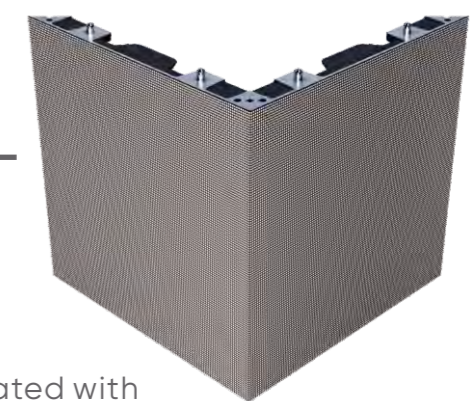
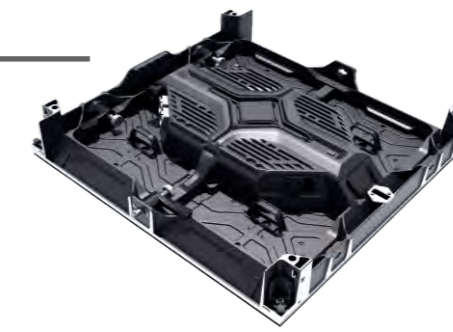
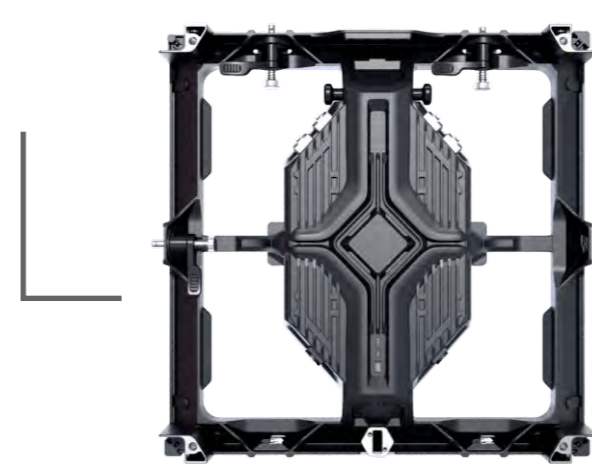

The die-casting cabinet is integrated with large hollow area and large space for installation and disassembly, and the heat dissipation is better.

GN PLUS SERIES INDOOR



Protect module from bumping



Easy maintenance



Unique lock shifts module



The heat dissipation of the control box is much better



Fast assembling

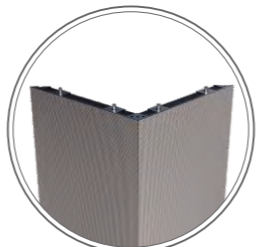

45°cut-corner cabinet is optional

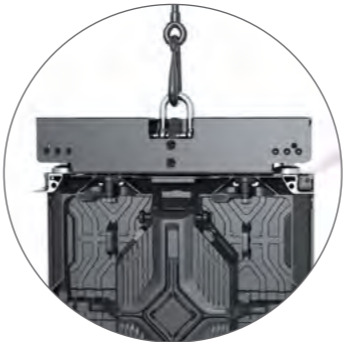

Hanging Bar



Stacking Structure

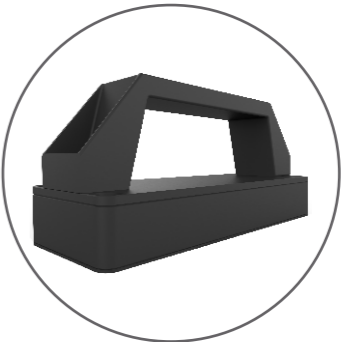

Front Maintenance Tool



Large And Small Cabinets Can Mix

FIXED

Series	GN1.5 PLUS	GN1.9 PLUS	GN2.6 PLUS	GN3.9 PLUS
LED type	SMD1212	SMD1515	SMD2121 / SMD1515	SMD2121
Pixel pitch	1.5mm	1.9mm	2.6mm	3.9mm
Pixel matrix per panel	320x320mm	256x256/512mm	192x192/384mm	128x128/256mm
Pixel per module	160x160	128x128	96x96	64x64
Pixel density	409600/sqm	262144/sqm	147456/sqm	65536/sqm
Module size	250x250mm	250x250mm	250x250mm	250x250mm
Weight	7.5kg/panel	7.5/12.5kg/panel	7.5/12.5kg/panel	7.5/12.5kg/panel
Refresh rate	3840Hz	3840Hz	3840Hz	3840Hz
Brightness	600nits	600nits	900nits	900nits
Max power	568w/m ²	446w/m ²	440w/m ²	360w/m ²
IP rating	IP40 / IP20	IP40 / IP20	IP40 / IP20	IP40 / IP20

FIXED

- User-Friendly
- Wide View Angle
- Noise Free
- Magnet
- Fast Installation
- Super Slim
- Easy Repair
- Good Heat Control
- High Contrast
- High Refresh Rate

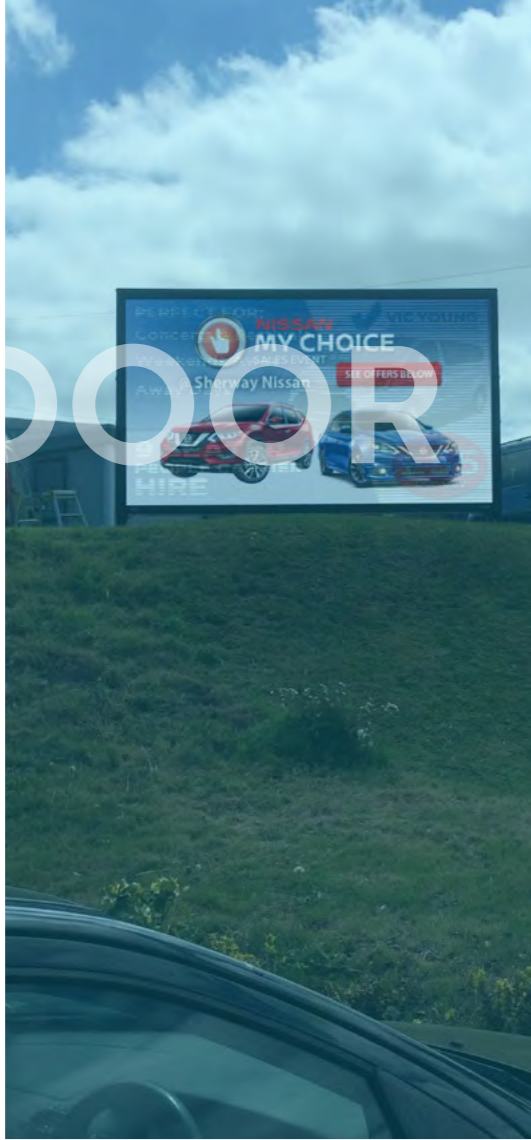

Outdoor Events

Billboard

Advertising

Building facade

OUTDOOR

OUTDOOR COMMERCIAL DISPLAYS

LST Series	Stabilize Your DOOH in All Weather	23
LSK Series	New Role for HD Outdoor	27
LX Series	Small for Wall, Smart for All	31



LST SERIES

STABILIZE YOUR DOOH IN ALL WEATHER

LST4 / LST6 / LST8 / LST10

Features

- Ultra High Cost Performance
- Die-cast aluminum bottom shell
- High tolerance of module to support normal work at 60°C
- 3840Hz and 14bits give outstanding visual effect
- Optional Configuration of Brightness and Module Bottom Case
- Front and Rear IP65 Protection

APPLICATIONS: TRANSIT ADVERTISING, BUSINESS STREE, SHOPPING MALL, STADIUMS, AIRPORT, OUTDOOR ADVERTISING, OUTDOOR LEISURE CENTURE, ETC



OUTDOOR COMMERCIAL DISPLAYS

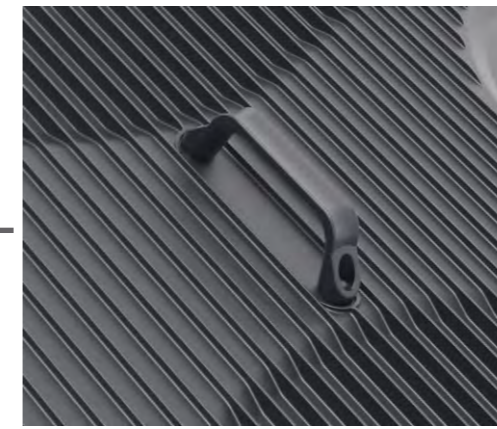

LST
MODULE

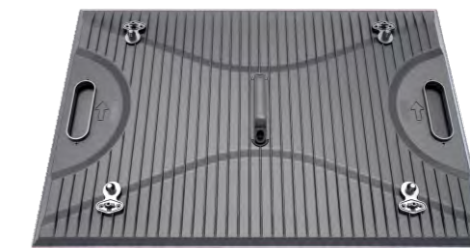

480x320mm

Module handles, 4PCS knobs





Aluminum cabinet optional

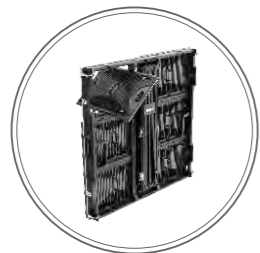

Quick operation access



Full front and rear maintenance



Fast installation

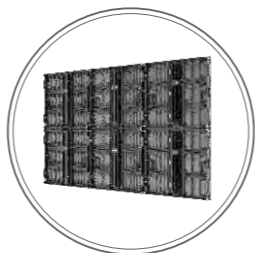

Hidden wiring between cabinets

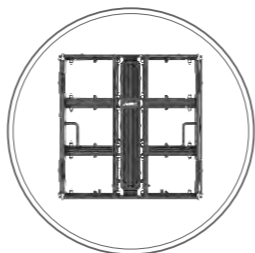

Fully-hollowed frame for heat dissipation



Front Maintenance Tool

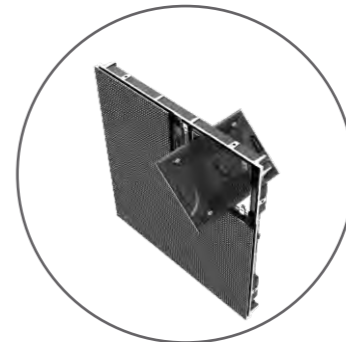

Rear Opening

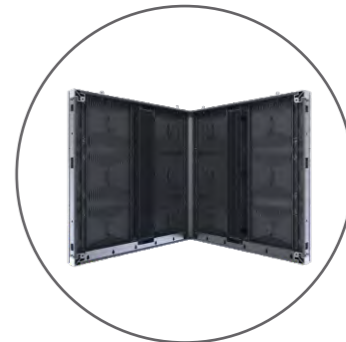

Splicing Of Right Angles

FIXED

Series	LST4	LST6	LST8	LST10
LED type	SMD1921	SMD2727	SMD2727	SMD2727
Pixel pitch	4.44mm	6.67mm	8mm	10mm
Cabinet Dimensions	960X960X91/108mm	960X960X91/108mm	960X960X91/108mm	960X960X91/108mm
Pixel matrix per module	108x72	72x48	60x40	48x32
Pixel density	56025/sqm	22500/sqm	15625/sqm	10000/sqm
Module size	480x320mm	480x320mm	480x320mm	480x320mm
Weight	25/26kg/panel	25/26kg/panel	25/26kg/panel	25/26kg/panel
Refresh rate	3840Hz	3840Hz	3840Hz	3840Hz
Brightness	5500-6500nits	6000-10000nits	6000-10000nits	6000-10000nits
Max power consumption	530-600w/m ²	640-750w/m ²	600-710w/m ²	600-710w/m ²
IP rating	IP65	IP65	IP65	IP65

FIXED



User-Friendly



Wide View Angle



Noise Free



Fast Installation



Super Slim



Easy Repair



Good Heat Control



Super Light



High Brightness



High Refresh Rate



LSK SERIES

NEW ROLE FOR HD OUTDOOR

LSK2.6 / LSK2.9 / LSK3.9 / LSK4.8 / LSK5.9

Features

- Creative anti falling Lock is special for outdoor
- Customized combination for naked-eye 3D solutions
- IP65 super high protection
- High Precision



APPLICATIONS: STADIUMS, RAILWA STATION SQUARES, AIRPORTS, PEDESTRIAN STREETS, BUS STATIONS, LEISURE WHARFS, ETC

OUTDOOR COMMERCIAL DISPLAYS

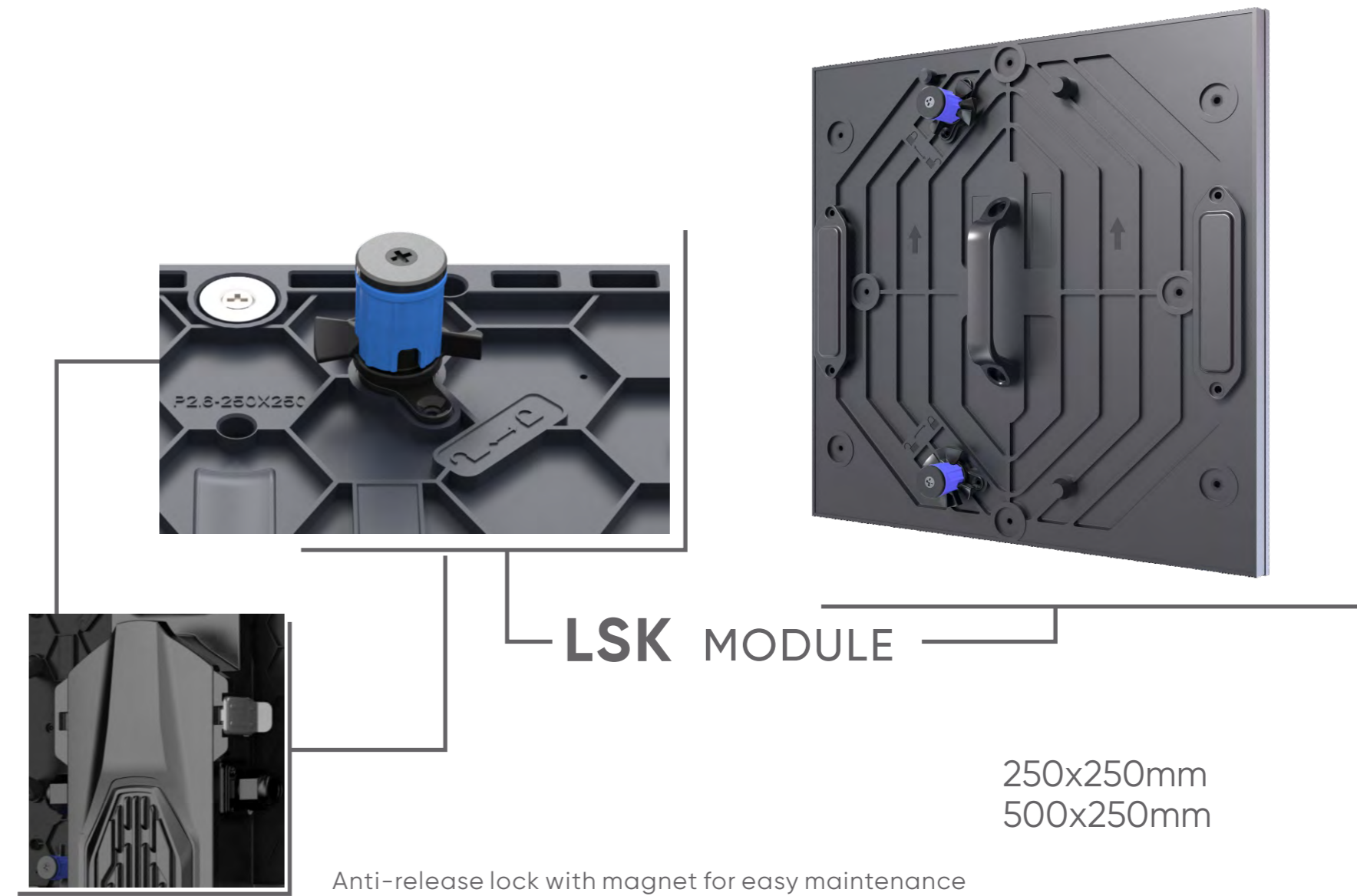



Integrated die-casting material



Control box service



Double handle

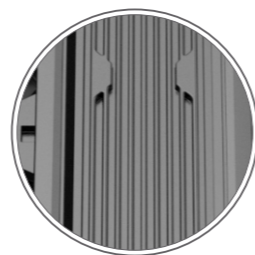

Heat dissipation design at the big die-cast control box



Anti-release Lock With Magnet



Front Maintenance

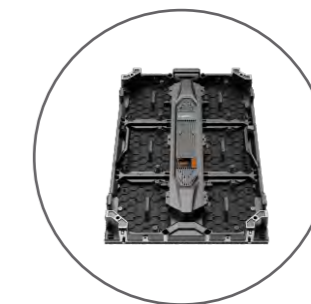

IP65 Super Protection

FIXED



User-Friendly



Wide View Angle



Noise Free



Fast Installation



Super Slim



Easy Repair



Good Heat Control



Super Light



High Brightness



High Refresh Rate

FIXED

Series	LSK2.6	LSK2.9	LSK3.9	LSK4.8	LSK5.9
LED type	SMD1516	SMD1516	SMD1921	SMD1921	SMD2727
Pixel pitch	2.6mm	2.9mm	3.9mm	4.8mm	5.9mm
Cabinet Dimensions	500X750/1000X82mm	500X750/1000X82mm	500X750/1000X82mm	500X750/1000X82mm	500X750/1000X82mm
Pixel matrix per module	96x96	82x82	128x64	104x52	84x42
Pixel density	147456/sqm	112896/sqm	65536/sqm	43264/sqm	28224/sqm
Module size	250x250mm	250x250mm	500x250mm	500x250mm	500x250mm
Weight	10.8/14.2kg/panel	10.8/14.2kg/panel	10.8/14.2kg/panel	10.8/14.2kg/panel	10.8/14.2kg/panel
Refresh rate	3840Hz	3840Hz	3840Hz	3840Hz	3840Hz
Brightness	5000nits	5000nits	5500-6500nits	5000-6500nits	5500-6500nits
Max power consumption	820w/m ²	800w/m ²	800w/m ²	640w/m ²	600w/m ²
IP rating	IP65	IP65	IP65	IP65	IP65

For reference only, subject to shipping parameters



LX SERIES

SMALL FOR WALL, SMART FOR ALL

L3.9X / L4.8X / L5.9X

Features

- High efficient heat dissipation
- Optional smart module with calibration storage function
- Aluminum profile is made as unibody
- Wireless connection, reducing failure rate
- The module size is 500x250mm
- Full front access and installation

APPLICATIONS: STADIUMS, THE COMMERCIAL PLAZAS, RAILWAY STATION SQUARES, AIRPORTS, PEDESTRIAN STREETS



OUTDOOR COMMERCIAL DISPLAYS

Simple and neat

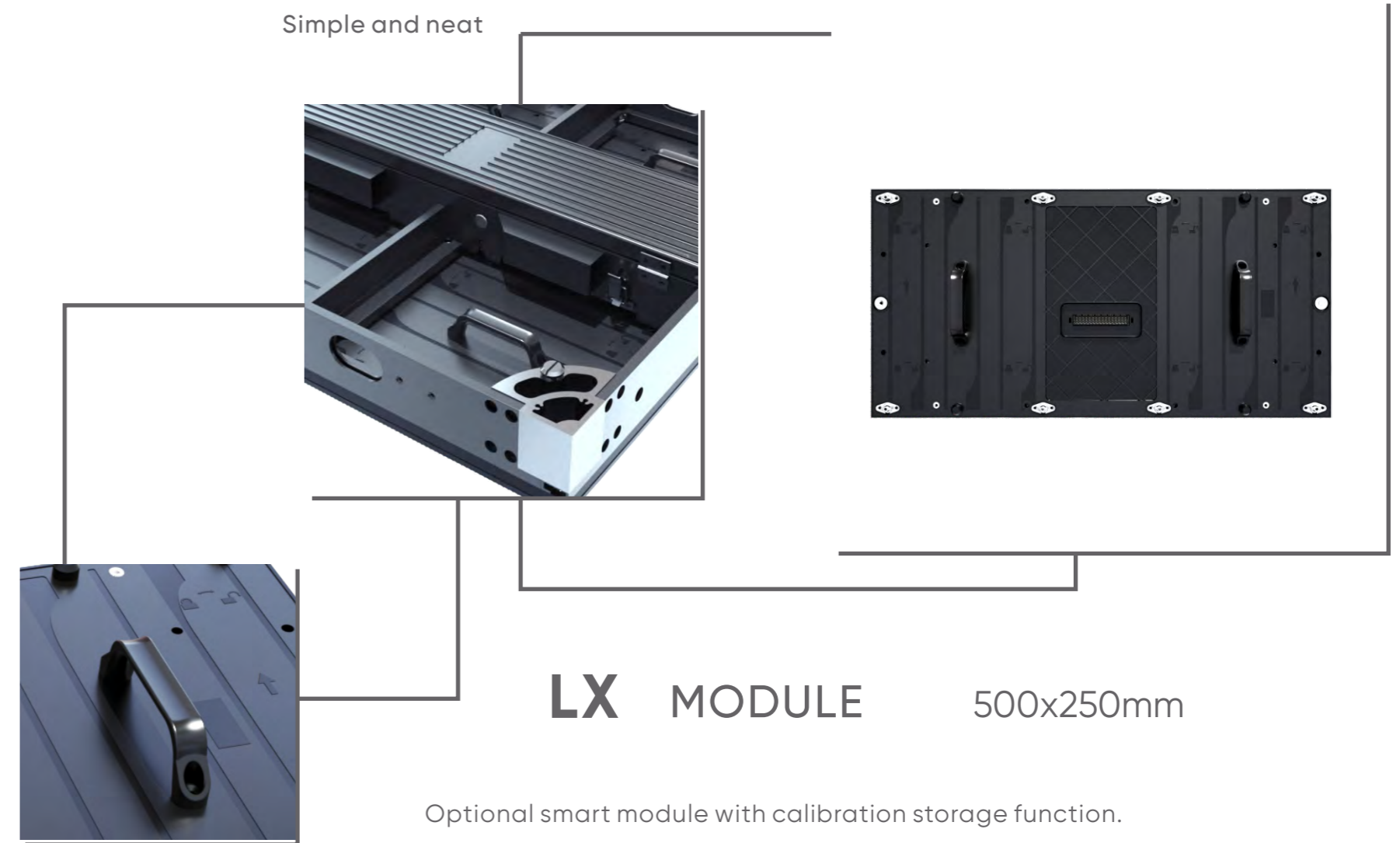

LX MODULE 500x250mm

Optional smart module with calibration storage function.

L3.9X / L4.8X / L5.9X

LX SERIES

OUTDOOR



Front Maintenance

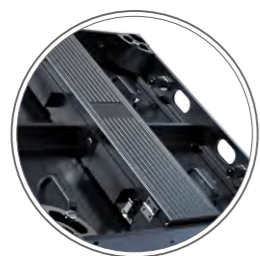

Accuracy



Positioning Pin



Simple Design



Side Lock Optional

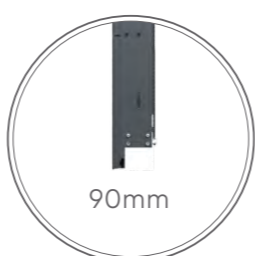

90mm

Super Slim



Front Tool



Aluminum Profile Is Designed For Better Flatness And Heat Dissipation And Stronger Deformation Resistance

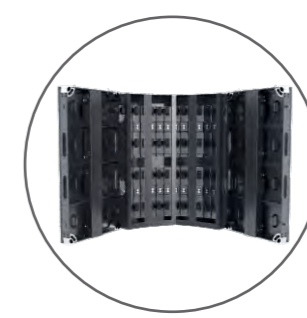

Combined With WX Series To Shape Smooth Curve



Modules Are Connected By Copper Sheets In Case Of Poor Contact And Misalignment Of Pin Headers

FIXED



User-Friendly



Wide View Angle



Noise Free



Fast Installation



Super Slim



Easy Repair



Good Heat Control



Super Light



High Brightness



High Refresh Rate

FIXED

Series	L3.9X	L4.8X	L5.9X
LED type	SMD1921	SMD1921	SMD2727
Pixel pitch	3.9mm	4.8mm	5.9mm
Cabinet Dimensions	500x500/750/1000x90mm	500x500/750/1000x90mm	500x500/750/1000x90mm
Pixel matrix per panel	128x128/192/256	104x104/156/208	84x84/126/168
Pixel density	65536/sqm	43264/sqm	28224/sqm
Module size	500x250mm	500x250mm	500x250mm
Weight	9/13/16kg/panel	9/13/16kg/panel	9/13/16kg/panel
Refresh rate	3840Hz	3840Hz	3840Hz
Brightness	5500-6500nits	5500-6500nits	5500-6500nits
Max power	800w/m ²	640w/m ²	600w/m ²
IP rating	IP65 / IP54	IP65 / IP54	IP65 / IP54

For reference only, subject to shipping parameters

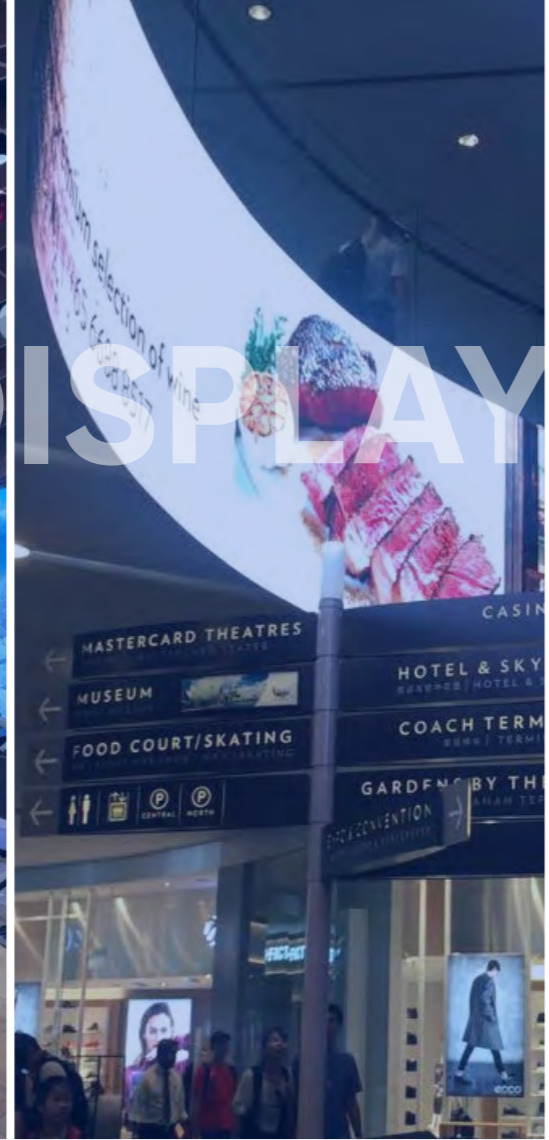
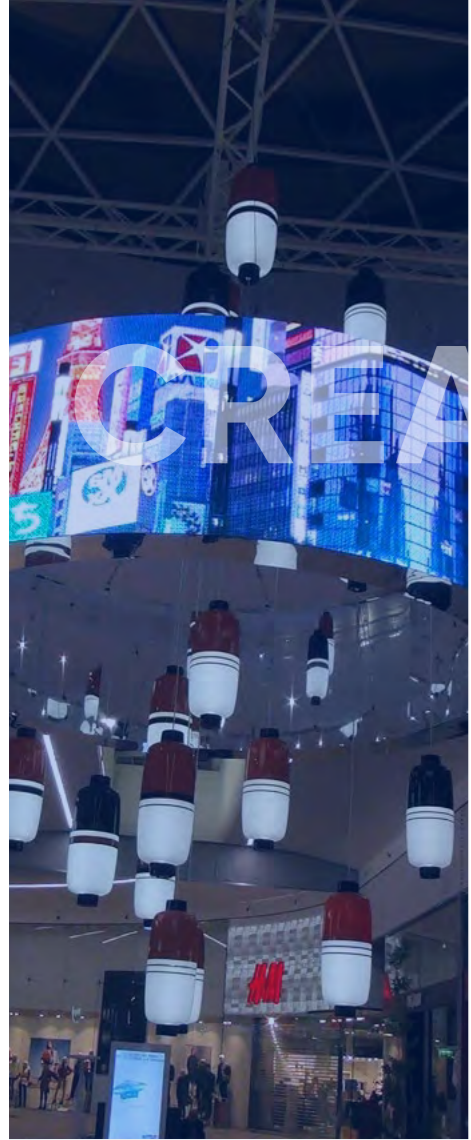

Commercial Decoration

Exhibitions

Public Infrastructure

Shopping Mall

CREATIVE DISPLAYS

LCF Series	Flexible Display, Creative Expert	37
WNX Series	Infinite Creativity for Indoor	41
WX Series	High Flexibility, Unlimited Creativity	45

LCF SERIES

FLEXIBLE DISPLAY, CREATIVE EXPERT

LCF1.5 \ LCF 2.6

Features

- Creative curved displays
- Front maintenance
- Thinner and Lighter
- Splicing with BNX
- Fast and safe installation
- 72° folding

APPLICATION: SHOPPING MALLS, EXHIBITION, TV SHOWS, LAUNCH CONFERENCES, ETC
CREATIVE CHANGES THE WORLD

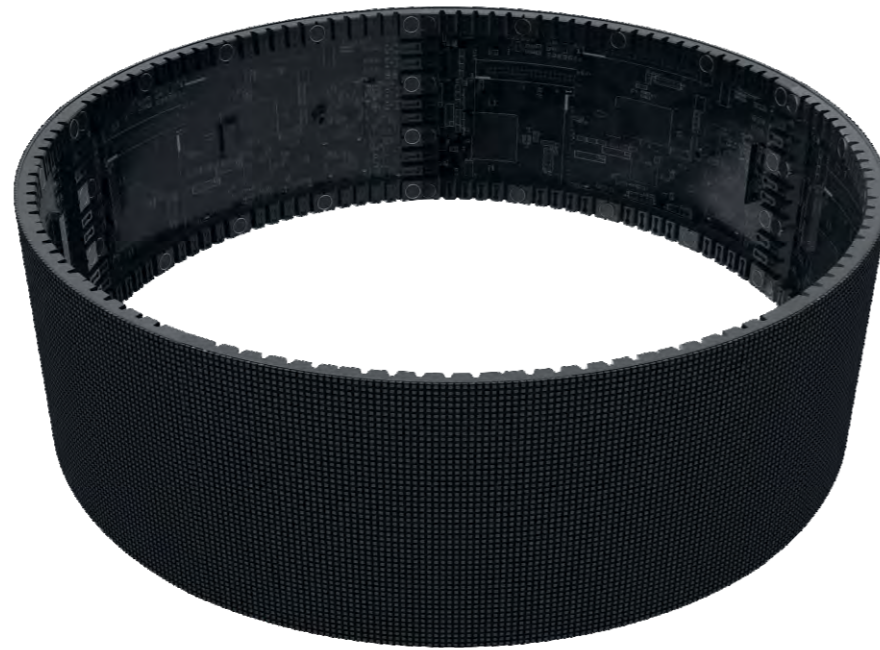

CREATIVE DISPLAYS



R240mm

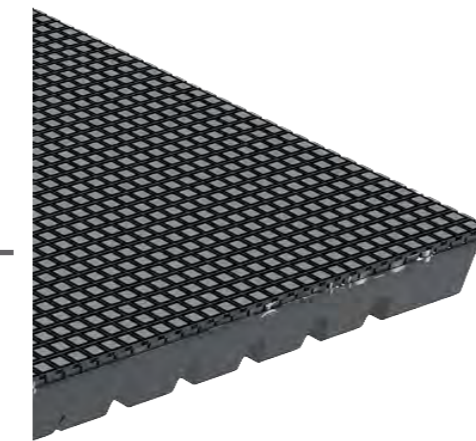
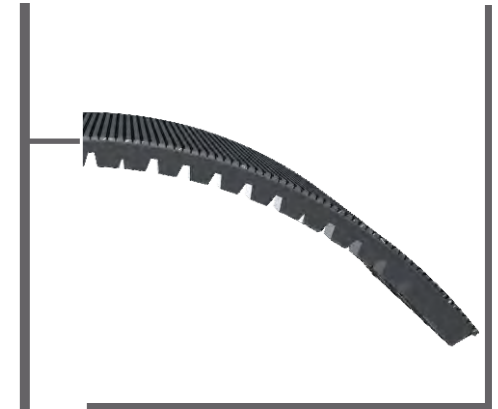

LCF

MODULE

250x125mm

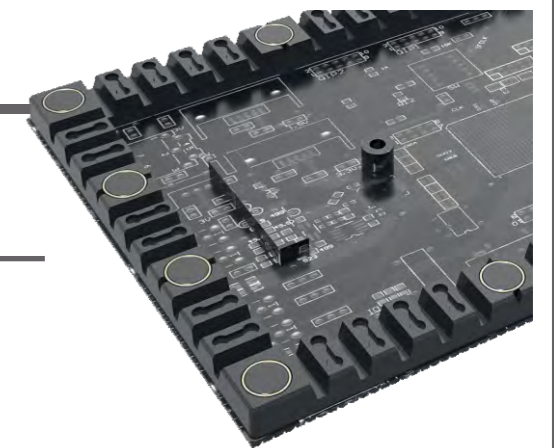

LCF1.5 \ LCF2.6

LCF SERIES

INDOOR



Ultra-slim and light



Front maintenance



Front maintenance tool

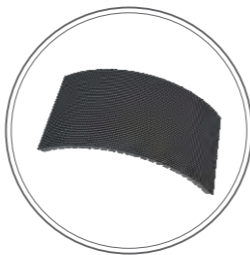

Wide visible angle



Flexible display

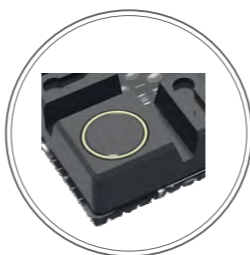

Magnetic location



72° Three-dimensional Folding



Combined With BNX Series

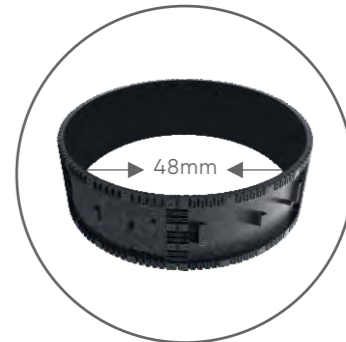

6 Modules Creat One Circle

CREATIVE

Series	LCF1.5	LCF2.6
LED type	SMD1212	SMD1515
Pixel pitch	1.5mm	2.6mm
Pixel matrix per module	160X80mm	96X48mm
Pixel density	409600/sqm	147456/sqm
Module size	250x125mm	250x125mm
Weight	0.21Kg/module	0.18Kg/module
Refresh rate	3840Hz	3840Hz
Brightness	600nits	800nits
Max power consumption	450w/m²	450w/m²
IP rating	IP40/IP20	IP40/IP20

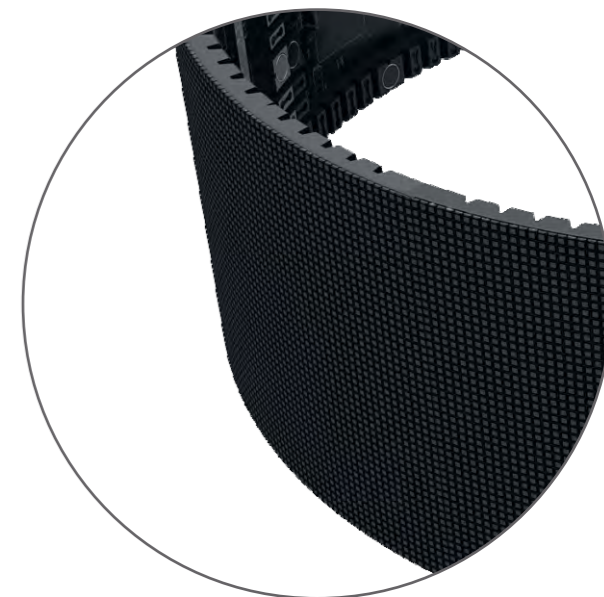

For reference only, subject to shipping parameters

- User-Friendly
- Wide View Angle
- Noise Free
- High Definition
- Magnet
- Fast Installation
- Super Slim
- Easy Repair
- Good Heat Control
- Super Light
- High Contrast
- High Refresh Rate

WNX SERIES

INFINITE CREATIVITY FOR INDOOR

WN1.9X / WN2.6X / WN3.9X

Features

- Creative curved displays
- Front and rear maintenance
- Integrated control box
- Ultra slim and light
- Fast maintenance
- Safe and pretty



APPLICATIONS: SHOPPING MALLS, MUSEUMS, LANDSCAPES AND BULLETIN BOARDS ETC.

CREATIVE DISPLAYS



R318.5mm

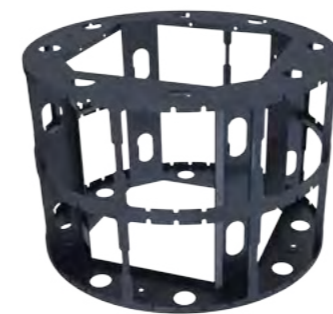

WNX
MODULE

250x250mm



WN1.9X / WN2.6X / WN3.9X
WNX SERIES

INDOOR



Ultra slim and light



Wide visible angle

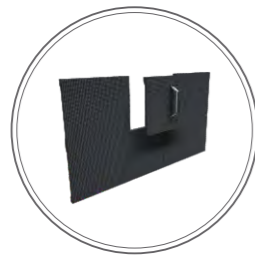

Front and rear maintenance

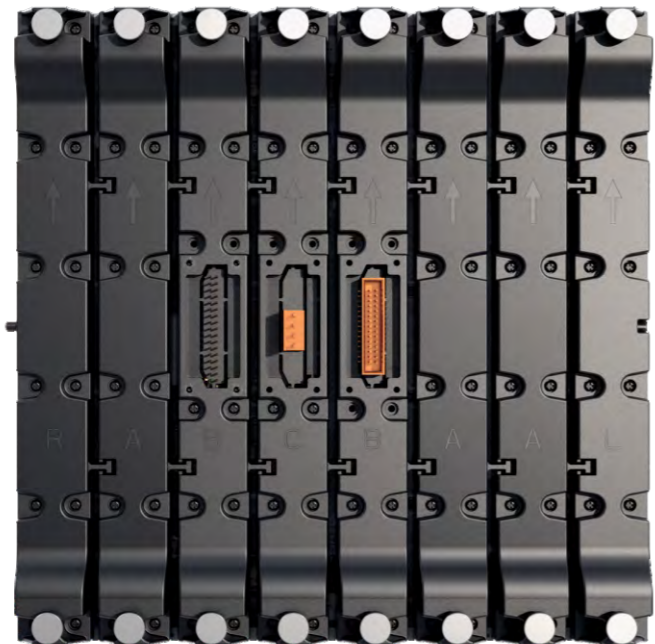

Independent control box



Flexible module



Creative curved displays,
Flexible and artistic



Control Box



Flat Wires

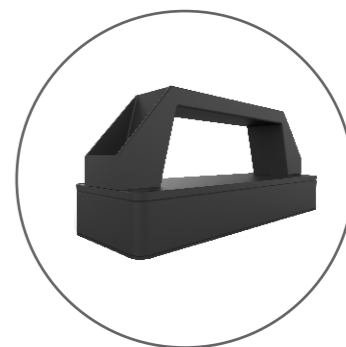

Maintenance Tool

CREATIVE

Series	WN1.9X	WN2.6X	WN3.9X
LED type	SMD1010	SMD2121	SMD2121
Pixel pitch	1.9mm	2.6mm	3.9mm
Module Dimensions	250x250	250x250	250x250
Pixel matrix per module	128x128	96x96	64x64
Pixel density	262144/sqm	147456/sqm	65536/sqm
Weight	0.75kg/module	0.75kg/module	0.75kg/module
Refresh rate	3840Hz	3840Hz	3840Hz
Brightness	600nits	800-900nits	800-900nits
Max power	437w/m ²	450w/m ²	420w/m ²
IP rating	IP40 / IP20	IP40 / IP20	IP40 / IP20



- User-Friendly
- Wide View Angle
- Noise Free
- High Definition
- Magnet
- Fast Installation
- Super Slim
- Easy Repair
- Good Heat Control
- Super Light
- High Contrast
- High Refresh Rate

WX SERIES

HIGH FLEXIBILITY, UNLIMITED CREATIVITY

WX2.9 / WX3.9 / WX4.8 / WX5.9

Features

- Outdoor High-density flexible screen
- Large radian
- High protection rating
- Front installation, front maintenance
- Splicing With LX and LSK



APPLICATIONS: SHOPPING MALLS, MUSEUMS, LANDSCAPES AND BULLETIN BOARDS ETC.

CREATIVE DISPLAYS

R318.5mm



WX
MODULE

250x250mm



WX2.9 / WX3.9 / WX4.8 / WX5.9
WX SERIES

OUTDOOR



Ultra slim and light



Wide visible angle

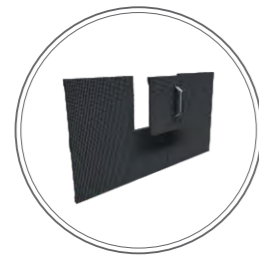

Front and rear maintenance



Independent control box



Flexible module



Creative curved displays,
Flexible and artistic



Control Box



Flat Wires



Maintenance Tool

CREATIVE

- User-Friendly
- Wide View Angle
- Noise Free
- High Definition
- Magnet
- Fast Installation
- Super Slim
- Easy Repair
- Good Heat Control
- Super Light
- High Contrast
- High Refresh Rate

CREATIVE

Series	WX2.9	WX3.9	WX4.8	WX5.9
LED type	SMD1515	SMD2121	SMD2121	SMD2727
Pixel pitch	2.9mm	3.9mm	4.8mm	5.9mm
Module Dimensions	250x250	250x250	250x250	250x250
Pixel matrix per module	84x84	64x64	52x52	42x42
Pixel density	112896/sqm	65536/sqm	43264/sqm	28224/sqm
Weight	0.75kg/module	0.75kg/module	0.75kg/module	0.75kg/module
Refresh rate	3840Hz	3840Hz	3840Hz	3840Hz
Brightness	4000nits	5000nits	5000nits	5000nits
Max power	840w/m ²	780w/m ²	564w/m ²	723w/m ²
IP rating	IP67(Controlbox:IP65)	IP67(Controlbox:IP65)	IP67(Controlbox:IP65)	IP67(Controlbox:IP65)



Monitoring Rooms

Public Infrastructure

TV Studios

Security

FINE PITCH DISPLAYS

LMini Series

Brand New COB Mini Product

51

LHP Series

High and Stable Integration NPP Series

55

HNA Series

Perfect Model of 16:9 High Resolution

59

LMini SERIES

BRAND NEW COB MINI PRODUCT

LMini 0.9/ LMini 1.2/ LMini 1.5/ LMini 1.8

Features

- Fully front maintenance, extreme light weight and slim
- Cool screen and energy saving
- Low blue light and 10000:1 high contrast ratio
- High flatness with XYZ alignment
- 9 strong protections
- 3-in-1 Integrated Design(optional)

Cabinet size: 600x337.5x29.6mm
Customizable cabinet: curving cabinet, corner cabinet, half-size cabinet

APPLICATIONS: CONTROL ROOM, CONFERENCE, MONITOR ROOM, EXHIBITION HALL, EDUCATION



FINE PITCH DISPLAYS

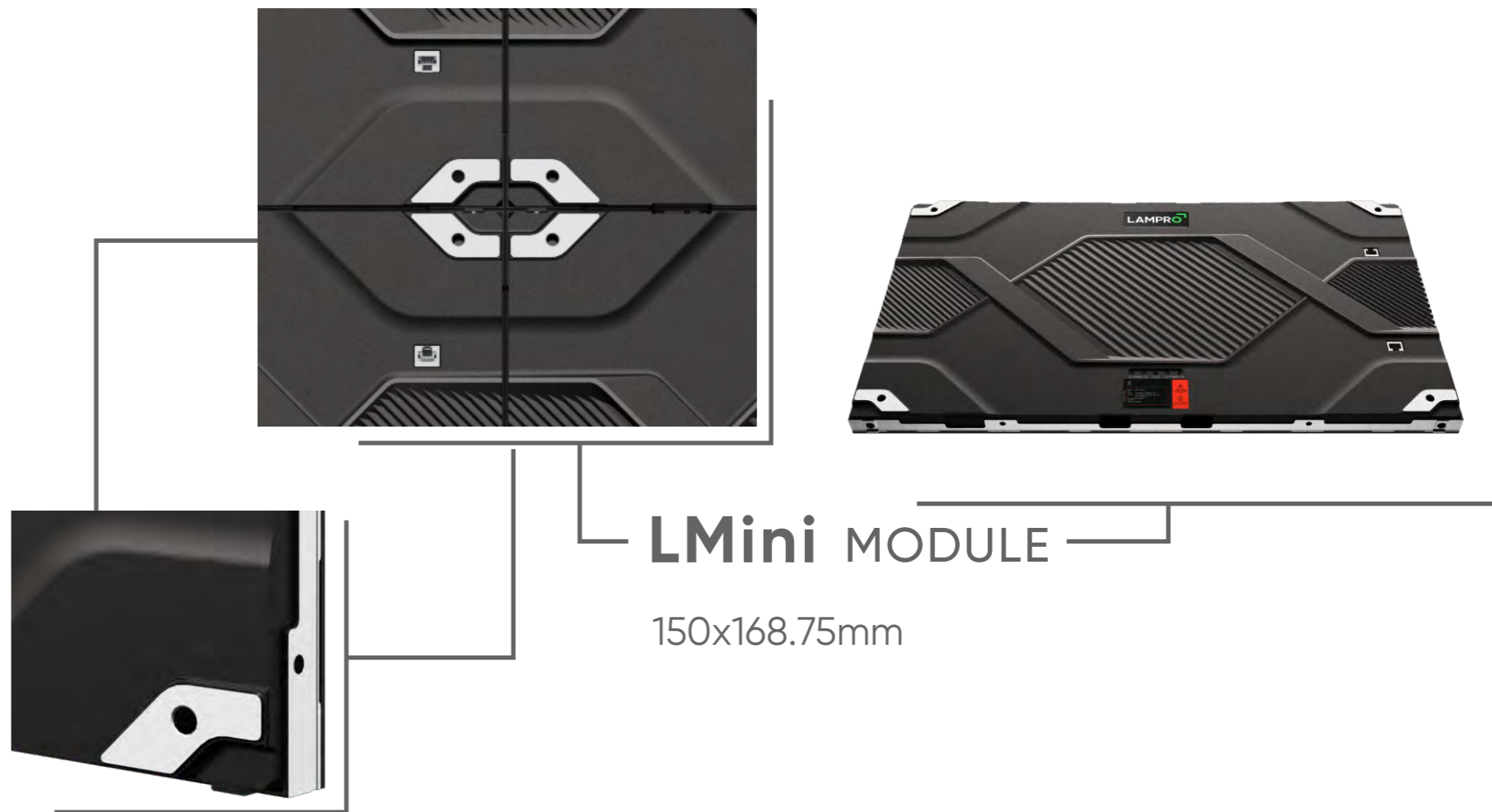

LMini MODULE

150x168.75mm

LMini 0.9 / LMini 1.2 / LMini 1.5 / LMini 1.8

LMini SERIES

INDOOR

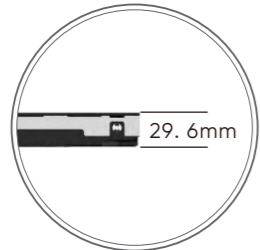

Ultra Slim and Light

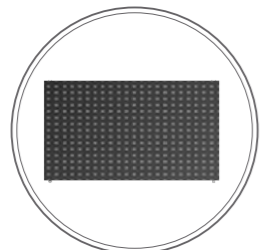

Wireless Module



XYZ alignment



Integrated die-casting material

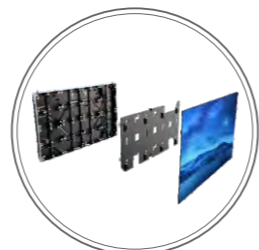

3-in-1 Integrated Design



Full Front Maintenance



Wide Viewing Angle



Strong Protection



Moisture-proof

INDOOR

Series	LMini 0.9	LMini 1.2	LMini 1.5	LMini 1.8
LED type	Fully flip chip COB	Fully flip chip COB	Fully flip chip COB	Fully flip chip COB
Pixel pitch	0.93mm	1.25mm	1.56mm	1.87mm
Cabinet Dimensions	640X360X29.6mm	480X270X29.6mm	384X216X29.6mm	320X180X29.6mm
Pixel density	113777/sqm	640000/sqm	409600/sqm	284444/sqm
Module size	150x168.75mm	150x168.75mm	150x168.75mm	150x168.75mm
Weight	4kg/panel	4kg/panel	4kg/panel	4kg/panel
Refresh rate	3840Hz	3840Hz	3840Hz	3840Hz
Brightness	600nits	600nits	600nits	600nits
Viewing Angle	0~180°	0~180°	0~180°	0~180°
Contrast ratio	10000:1	10000:1	10000:1	10000:1
AC Input Power Max(W/Panel)	52	45	40	38
IP rating	Rear IP50	Rear IP50	Rear IP50	Rear IP50

INDOOR

- Super Light
- Super Slim
- Energy Saving
- 9 Strong protections
- EBL+
- Good Flatness
- Wide Viewing Angle
- Simple Installation
- Low Carbon
- Wireless Module

LHP SERIES

HIGH AND STABLE INTEGRATION NPP SERIES

LHP0.9 / LHP1.2 / LHP1.5 / LHP1.8 / LHP2.5

Features

- High Integration
- Wireless Connection
- Hidden Wiring Design
- Lighter Design
- 16:9 Golden Ratio



APPLICATIONS: CONTROL ROOM, CONFERENCE, MONITOR ROOM, EXHIBITION HALL, EDUCATION

FINE PITCH DISPLAYS

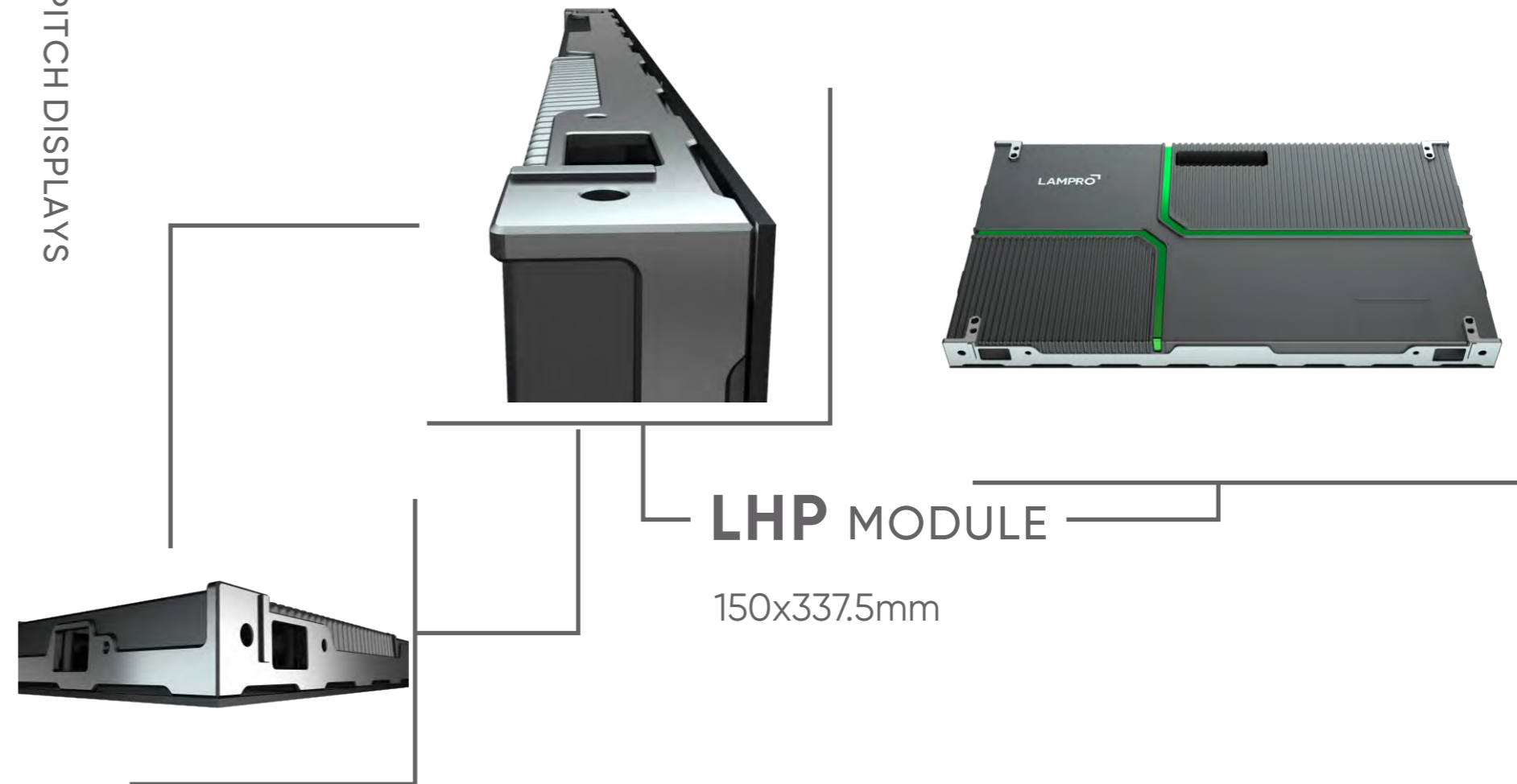

LHP0.9 / LHP1.2 / LHP1.5 / LHP1.8 / LHP2.5

LHP SERIES

INDOOR



4KG/Panel

Light weight



Cabinet curved design



High integration



16:9 Golden Ratio



High protection

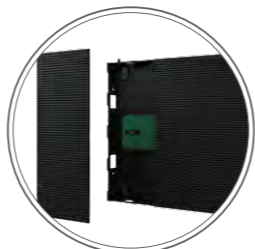

Full Front Maintenance

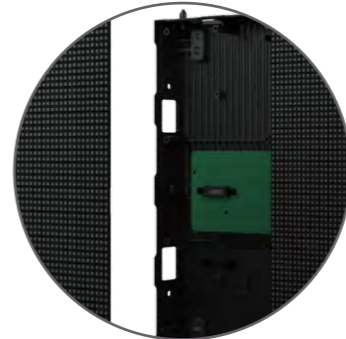

Wireless modules

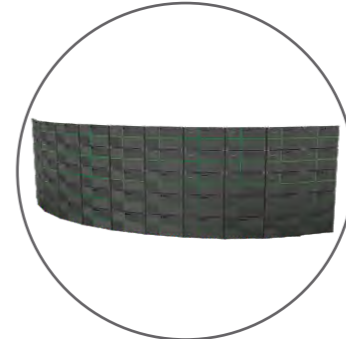

Concave splicing



Cut corner 45°

FINE PITCH

Series	LHP 0.9	LHP 1.2	LHP 1.5	LHP 1.8	LHP 2.5
LED type	IMD 4 in 1	1010	1212	1515	2121
Pixel pitch	0.9mm	1.2mm	1.5mm	1.8mm	2.5mm
Panel Size(mm)	600x337.5x45	600x337.5x45	600x337.5x45	600x337.5x45	600x337.5x45
Pixel density	113777/sqm	640000/sqm	409600/sqm	284445/sqm	160000/sqm
Module size	150x337.5mm	150x337.5mm	150x337.5mm	150x337.5mm	150x337.5mm
Weight	4kg/panel	4kg/panel	4kg/panel	4kg/panel	4kg/panel
Refresh rate	3840Hz	3840Hz	3840Hz	3840Hz	3840Hz
Brightness	600nits	600nits	600nits	600nits	800nits
Horizontal / Vertical Viewing Angle(°)	160°/ 160°	160°/ 160°	160°/ 160°	160°/ 160°	160°/ 160°
Contrast ratio	5000:1	5000:1	5000:1	5000:1	5000:1
AC Input Power Max(W/Panel)	*	548	494	445	371

FINE PITCH



Super Light



Energy Saving



Good Flatness



Wide Viewing Angle



Simple Installation



Low Carbon



Wireless Module

HNA SERIES

PERFECT MODEL OF 16:9 HIGH RESOLUTION

HN0.9A / HN1.2A / HN1.5A / HN1.8A

Features

- 16:9 ratio standard screen
- HDR HD display
- 4 in 1 and 2 in 1 pixel integration, professional display
- Intelligent modules
- Double backup of PSU and signal
- Cabinet curved design
- Full front maintenance

APPLICATIONS: RETAIL SHOPS ,CHAIN STORES,TV STUDIOS,CINEMAS,AIRPORTS,MUSEUMS

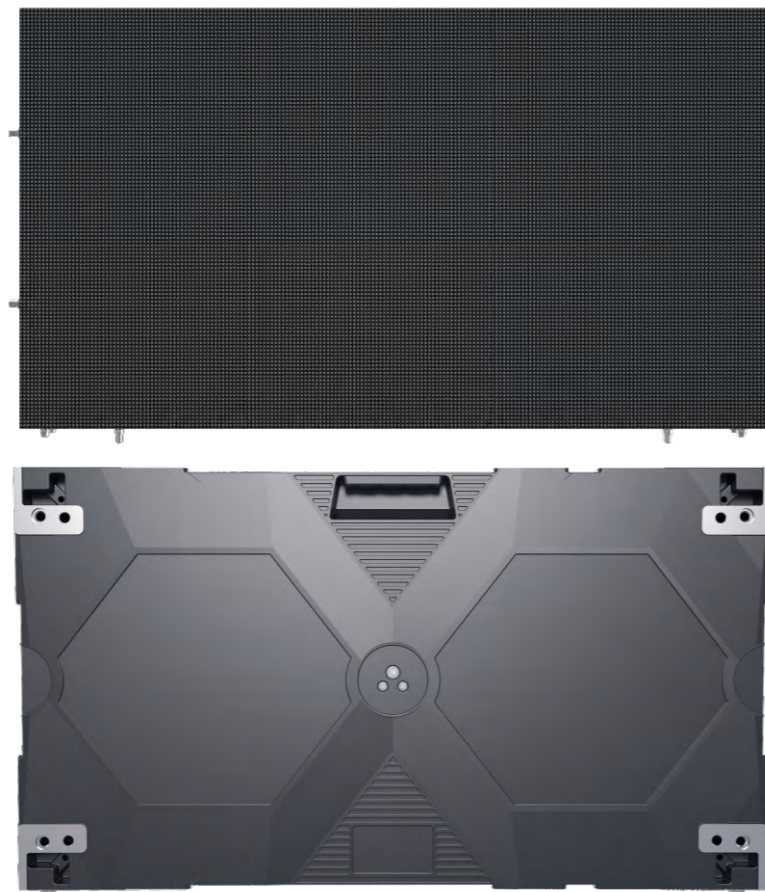

FINE PITCH DISPLAYS

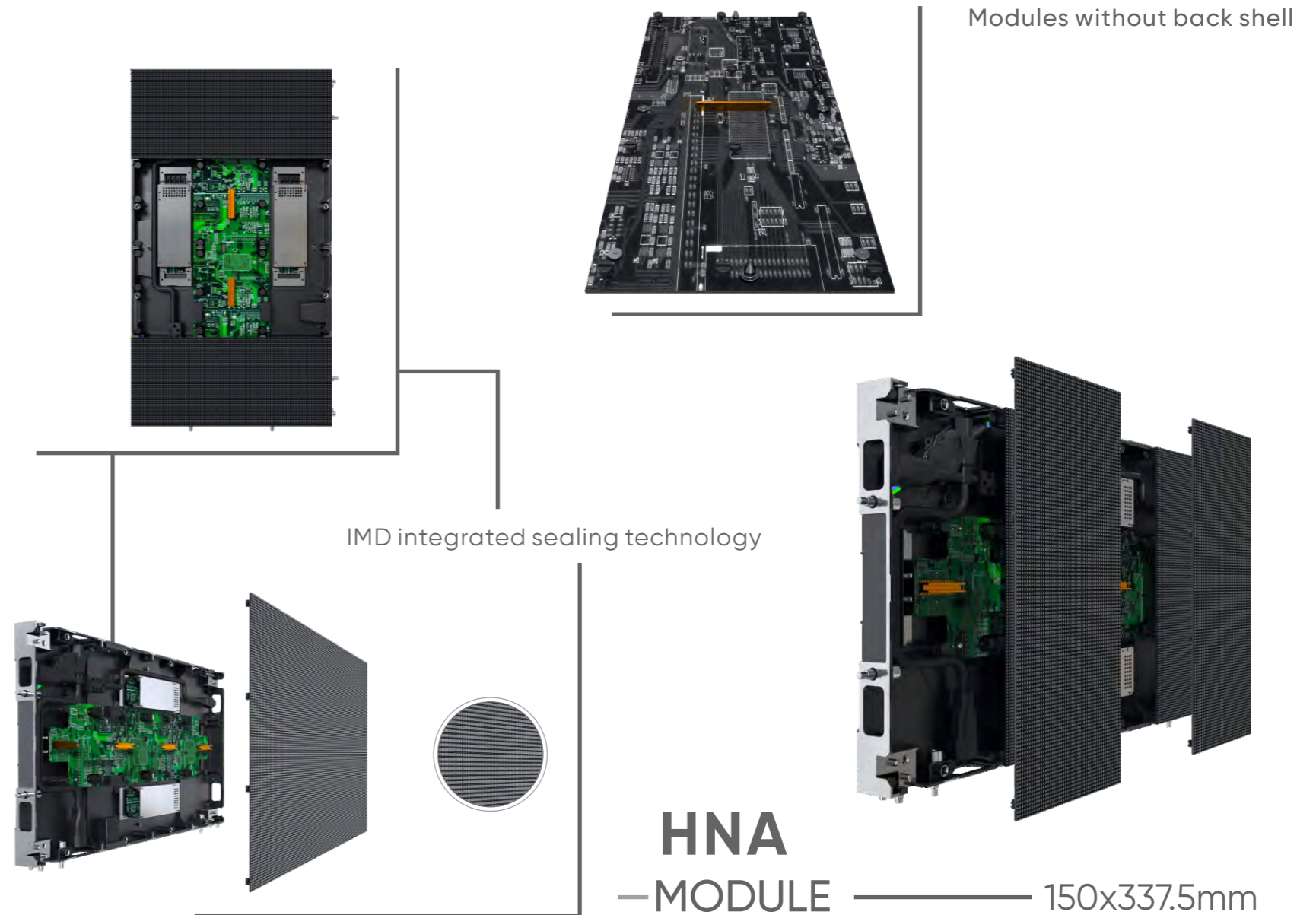

HNO.9A / HN1.2A / HN1.5A / HN1.8A

HNA SERIES

INDOOR

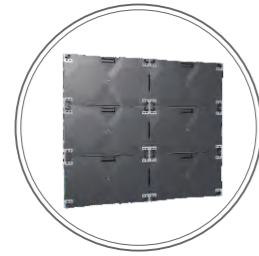

Hidden wiring design

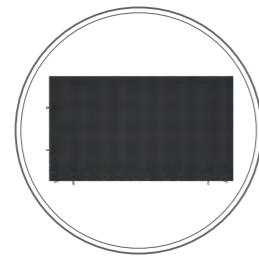

16:9 ratio screen

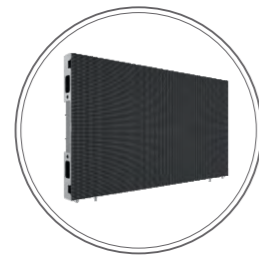

Smart module



PCB



Curved cabinet



Cabinet curved design



Front Maintenance Tool

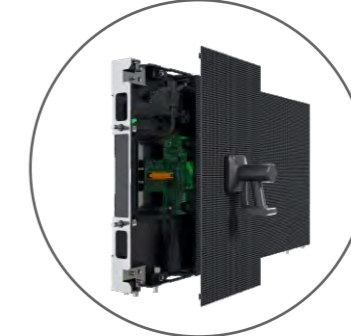

Full Front Maintenance

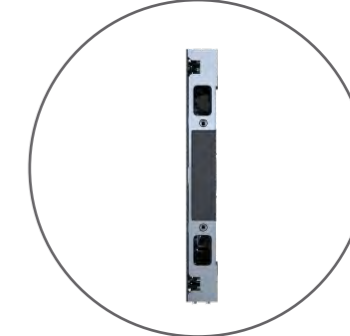

Super Slim

INDOOR

Series	HNO.9A	HN1.2A	HN1.5A	HN1.8A
LED type	4in1	SMD1010	SMD1010 / SMD1212	SMD1515
Pixel pitch	0.9375mm	1.25mm	1.5625mm	1.875mm
Cabinet Dimensions	600X337.5X40mm	600X337.5X40mm	600X337.5X40mm	600X337.5X40mm
Module Resolution	160x360	120x270	96x216	80x180
Pixel density	1137777/sqm	640000/sqm	409600/sqm	284444/sqm
Module size	150x337.5mm	150x337.5mm	150x337.5mm	150x337.5mm
Weight	5.5kg/panel	5.5kg/panel	5.5kg/panel	5.5kg/panel
Refresh rate	3840Hz	3840Hz	3840Hz	3840Hz
Brightness	600nits	600nits	600nits	800nits
Max power consumption	480w/m ²	540w/m ²	496w/m ²	450w/m ²
IP rating	IP40 / IP20	IP40 / IP20	IP40 / IP20	IP40 / IP20

INDOOR



User-Friendly



Wide View Angle



Noise Free



Fast Installation



Super Slim



Easy Repair



Good Heat Control



Super Light



High Brightness



High Refresh Rate



Changsha Subway Digitalart Museum

which won the International Masterprize and "Muse Design Award" top Architecture Awards of American Architecture



WN2.6X+BN2.5X, Dubai



HN1.2A, Spain



LF10, USA

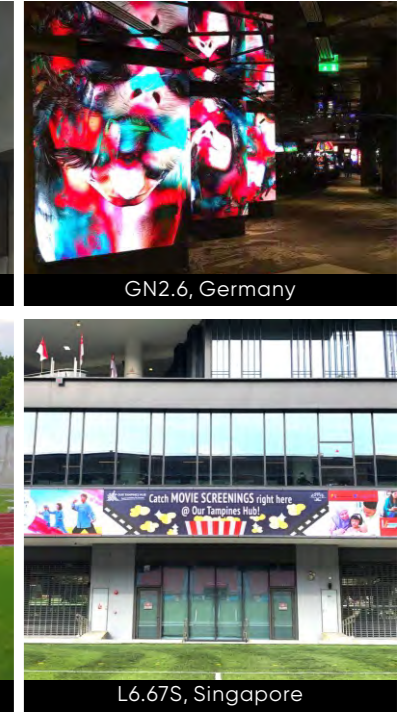

L6.67S, Singapore

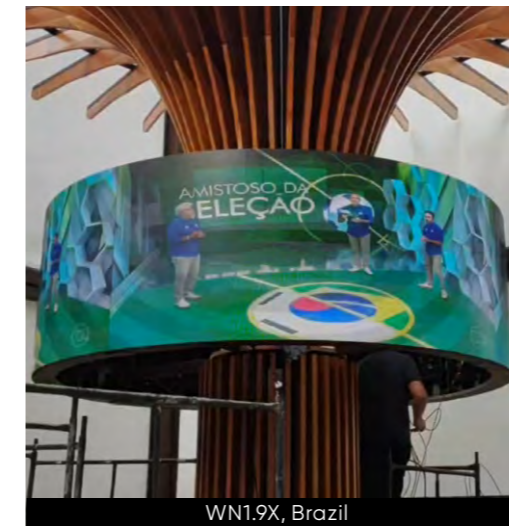

WN1.9X, Brazil



BN1.5X, Oman



BN2.6X, Norway

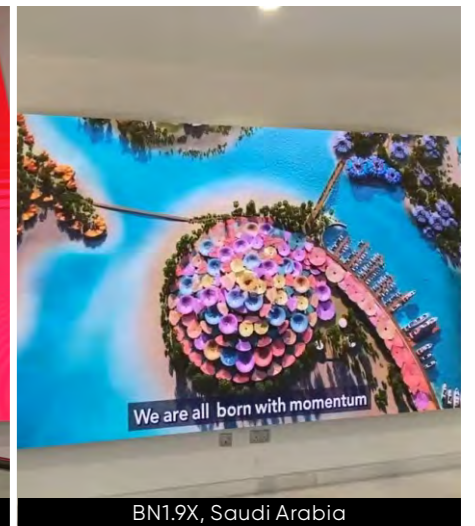

BN1.9X, Saudi Arabia

FOCUS ON CHANNEL DISTRIBUTION



Strategic Customer Development

Distribution Channel Co-building



Flexible Price System

Competitive & Reasonable



Diverse Product Selection

Module Product Line Supplement & Different Positioning & High Performance



Global Localization Service

Onsite & Online Prompt Response



Marketing Opportunities

Exhibition & Showroom Co-building